

WHAT YOU NEED TO KNOW - THE IC706MK2

WYNTN-01, revision 2 by: Ian Jackson VK3BUF

INTRODUCTION

The IC706MK2 is a multi-band transceiver capable of receiving from just 30KHz to 200MHz. It can transmit on all the amateur bands from 160 metres through to 2 metres. It supports all the common modes of operation, AM FM SSB CW RTTY. Transmitter power on HF/6M is 100 Watts of SSB. On 2M FM it is 20 Watts.

Note that there is also a MK1 version (IC706), which has lower output power on some bands and did not come with digital receiver filters. There is also the IC706MKIIG version which also supports UHF operation on 70cm. (This document should not be used on the 'G' version.)

It is a versatile radio, great for mobile or shack use. However there are a lot of buttons and menu settings, which makes it difficult to operate without some training and handy notes.



1. POWERING ON AND OFF

This is a simple operation. To activate the radio, briefly press the **POWER** button in the top Left-Hand corner of the front panel. To turn it OFF, press and hold the same button for 2 seconds.

2. BAND SELECTION

On the front Right-hand edge of the radio there are two arrow buttons labelled '**BAND**'. Pressing the upper button will step the transceiver upwards through the normal amateur bands. The lower Right-hand button will step the radio down the bands.

3. MODULATION MODE SELECTION

Mostly the radio will remember the last mode of operation used on each band, so modulation modes will usually change automatically when swapping from HF to VHF.

However, pressing the **MODE** button at the top, just to the left of the VFO knob will cycle the radio through different Mode selections of **USB LSB CW RTTY FM WFM** (wide FM) and **AM**.

OPERATING MODE SELECTION

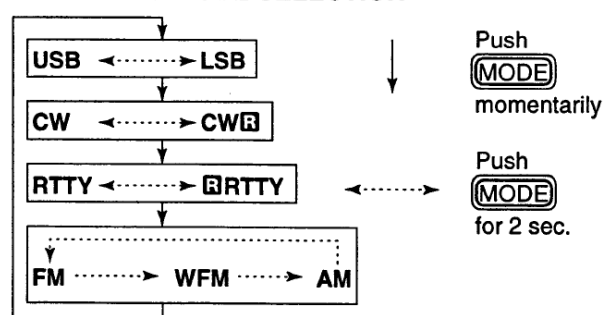

4. SELECTING A VFO FREQUENCY

To use the VFO for dialling up a given frequency it is important to consider how the rig was last being used. It is possible that a couple of these steps can be skipped.

The large VFO knob could be 'locked' to prevent accidental rotation. Just below and to the left of the VFO knob is a button labelled **LOCK** with a red light next to it. If the red light is ON, then press the **LOCK** button to turn the lamp off and unlock the VFO control. Once you establish a contact pressing **LOCK** again could be good, as on a bumpy road the knob could move a bit.

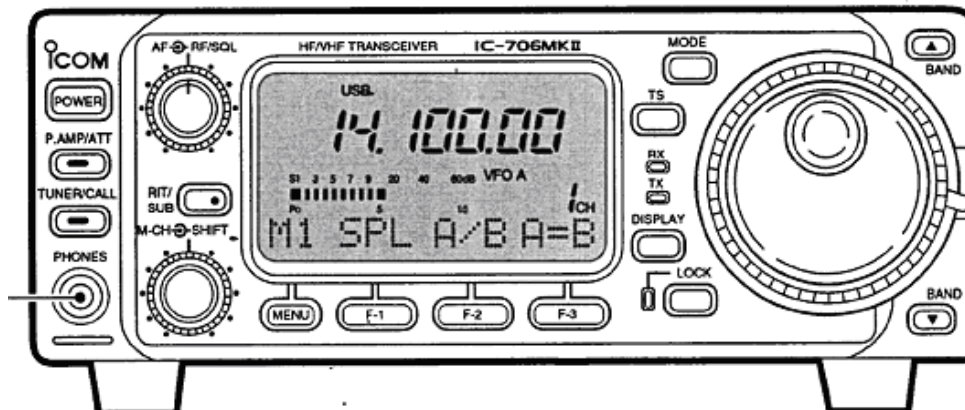

Next we must put the screen menu onto the correct level. Just below the display and to the left is the **MENU** button. Press this button a few times until the text on the display above the menu button says **M2**. To the right of the **MENU** button is another button labelled **F-3**. Pressing this button will reveal one of two selections. **VFO** for dial selection or **MEMO** for frequency Memories. Press the **F-3** button until **VFO** is shown. The main dial should now be capable of selecting a frequency to operate.

5. SETTING REPEATER OFFSETS

Repeater offsets are a convoluted process on this model. First we must ensure the repeater offset frequency is set to **-600** for transmitting 600KHz below the receive frequency, also called a *'negative offset'* or **600** (no minus sign) for a *'positive offset'* of the transmitter frequency.

To check the present offset, turn the radio **OFF**, then while holding down the **LOCK** button, turn the radio back **ON** again. This will put the radio into a special setup area. A setting number will appear in the lower left-hand corner of the screen. Using the **Band Up** and **Band Down** arrow buttons step through the settings until setting **17 DUP OFFSET** appears on the display. The present offset in KHz will also be revealed on the display. Rotate the main dial until 600 or -600 is shown, depending upon the present repeater requirement. When this has been done, turn the power **Off** and back **On** again to restore normal operation. The repeater offset has now been stored against the 'Split' function built into the radio. (Note that the IC706MKIIG uses a quite different process for repeaters than the non 'G' versions of this radio)

Next we must engage **SPLIT** operation to use the stored offset. Press the **MENU** button until **M1** is shown. The letters **SPL** should be present above the **F-1** button. Pressing the **F-1** button turns the **SPLIT** feature on or off. The repeater split is armed when the letters **SPL** appear in the top right-hand corner of the display. Now when the PTT button is pressed, the display frequency will change by the offset amount. If this frequency is subsequently saved to a memory channel, then the present offset will be saved as well.

(If a sub-audible tone (CTCSS) needs to be applied to the repeater as well, see the next section)

6. SETTING SUBAUDIBLE TONES (CTCSS)

To add a sub-audible tone to the transmitted signal, the **SET** mode must be accessed. Press & hold the **DISPLAY** button for 2 seconds to enter this mode.

Next use the **BAND UP** or **BAND DOWN** buttons to reach setting **Q4** (repeater tones). On level **Q4**, rotating the main **VFO** knob should reveal one of the many standard tone frequencies available. (GGREC repeaters use **91.5Hz**) When the correct tone has been selected, press the **DISPLAY** button again to leave the **SETTINGS** area.

Even though the tone frequency has now been set, the feature must be activated before it will work. Press the **MENU** button until **M4** is revealed on the display. Press the **F-3** button until the **-T** indicator shows near the top right-hand corner of the display. With the **-T** indicator present, the sub-audible tone selected via the **Q4** setting will be added to any FM transmission. If this frequency is subsequently saved to a memory channel, then the present sub-audible tone will be saved as well.

7. SAVING & RECALLING MEMORY FREQUENCIES

After a VFO frequency, transmission mode, have been selected, along with applicable repeater offsets and tones, it is ok to write this configuration to a memory position for future access.

SAVING TO A MEMORY

Press the **MENU** button until **M2** is revealed on the display. Rotate the **M-CH** knob until a memory channel number is shown that has not previously been allocated. This is signified by the word **'Blank'** on the display. The **M-CH** knob is the centre control knob just to the left of the **MENU** button. Now press the **F1** button to write the current **VFO** settings to that memory position. (Note that this radio is capable of storing a title or name for each memory)

RECALLING A MEMORY

This is similar to making the **VFO** selection in paragraph 4. Just below the display and to the left is the **MENU** button. Press this button a few times until the text on the display above the menu button says **M2**. To the right of the **MENU** button is another button labelled **F-3**. Pressing this button will reveal one of two selections. **VFO** for dial selection or **MEMO** for frequency Memories. Keep stepping through these options until **MEMO** is shown. Stored memory selections may now be made by rotating the **M-CH** knob, just to the left of the **MENU** button.

8. ADJUSTING POWER OUTPUT

To change the transmitted power levels, the **SET** mode must be accessed. Press & hold the **DISPLAY** button for 2 seconds to enter this mode.

Next use the **BAND UP** or **BAND DOWN** buttons to reach setting **Q1 (RF POWER)**. On level **Q1**, rotating the main **VFO** knob should reveal one of eleven different transmitter power levels, from **L** for **LOW**, then settings **1** to **9**, then **H** for **HIGH**. When the correct power level has been selected, press the **DISPLAY** button again to leave the **SETTINGS** area.

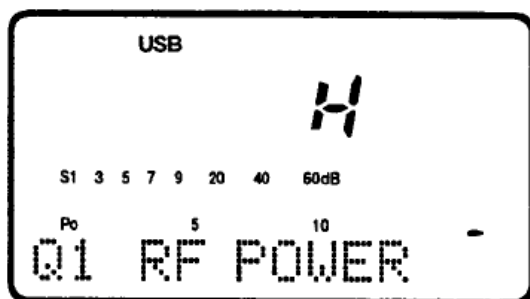

Maximum output power is selected.

9. SPECIAL COMMENTS

The IC706MK2 has two SO239 antenna sockets. The Upper socket is for HF and 6 Metres. The Lower socket is for the 2 Metre band only.